

<b>Investigation Report</b>		
<b>Investigation Site</b>	Moot Hall, Elstow (nr. Bedford)	
<b>Investigation Date</b>	23/09/2023 (into 24/09/2023)	
<b>Report By</b>	Dee Lindley & Jason Hollis	
<b>Team Members</b>	Andy, Ben, Dee, Jason, Laura, Maria, Rachel W	
<p><b>Weather conditions:</b> breezy, fairly mild, cold later at night</p> <p><b>Extraneous sounds:</b> Voices of occasional passers-by; cars/traffic (both near and distant); occasional fireworks; occasional aircraft (distant); occasional sirens; a few light gusts of wind.</p> <p><b>Extraneous visuals:</b> occasional car headlights from nearby church carpark and more distant roads.</p> <p><b>Interior observations:</b> temperature generally comfortable; loud clocks (on the wall and a grandfather clock); well-lit but very dark when lights out; security lighting; uneven floors (both stone and wooden); old beams; mostly wooden construction; a lot of wooden furniture items from different periods (including medieval, Jacobean and Civil War); many glass-fronted display cases, exhibits on the walls and some standalone items, such as Bedford Gaol door(s) and medieval pulpit.</p> <p><b>Dee's notes:</b> On entering Moot Hall behind member Ben, Dee is immediately aware of a small child in the lobby area sticking very close to Ben. Dee senses the child is following him/attracted to him for some reason. This is a very strong presence/energy indeed, so Dee has no doubt about what she is sensing (though she is not able to see the child). The impression Dee is getting is that the child is very small and may be around 8 years old (but it's difficult to know for sure when dealing with energies). She leans to the child being male. Also, Dee feels that a "J" name (John - or maybe James?) is relevant to the location, though she can't quite directly link it to the child, who is not giving his name.</p> <p>Dee wanders around the venue prior to the official start of the investigation to get a feel for the energies present. Upstairs, Dee is immediately drawn to the large horizontal beams and even sets her camera on the top of them to take photos, wanting to 'see the room from that perspective'. This seems important, as it's not something Dee would normally do on an investigation.</p> <p>Dee is aware of more than one child in the building and feels strongly that the building has religious connections.</p> <p>Prior to the investigation Andy places several film cameras around the building, in the Bunyan Room and the upstairs hall room. Jason also places a motion activated night-vision camera in the upstairs hall room, directed towards an iron chandelier hanging above the dining table in the centre of the room. This chandelier has been reported to swing seemingly of its own accord, although that did not happen on this occasion.</p> <p><b>Session 1: Downstairs - area at the pulpit end of the room (20:26 - 20:40)</b></p> <p><b>20:26</b> Protection prayer. At the end of which Dee hears a child's voice repeat the 'Amen'. The Protection Prayer is repeated, in case it happens again, and Dee feels it is necessary for the group to follow that with The Lord's Prayer.</p>		

**20:29** Andy confirms the temperature is 19.2 C

Maria: "Can we be quiet? Can you hear banging?"

**Debunk:** The 'Banging' noise (more like a low thud) is caused by a grandfather clock.

**20:30** Rachel (recovering from a recent bout of Covid) uses her inhaler.

**20:31** Dee senses movement nearby to her right (she is seated with her back to the pulpit, Rachel to her left, no one to her right).

**20:32** Andy announces that his MEL meter is dead. New batteries are completely flat. K2 EMF meter between Andy and Jason (on Andy's left, with an empty chair between them) flickers into yellow.

**20:35** Dee mentions that she senses the little kids moving around.

**20:36** K2 EMF meter flickers into yellow

**20:37** A noise occurs near the doorway to the lobby (?)

**20:39** Dee feels that the kids are playing - going round the display cases then back again. The K2 EMF meter flickers into yellow again.

**Debunk:** The EMF meter is found to be resting on top of Andy's mobile phone.

**20:40** End of session.

---

## Session 2: Same area - SB7 with headphones & blindfold (20:44 - 21:01)

Maria is seated at the far end of the room beyond the display cases with her back to the rest of the members. She is wearing noise-cancelling headphones to listen to the spirit box while the rest of the team quietly asks questions. Maria will call out any words/sounds she hears from the SB7.

**20:44** Dee - How many of you are here?

Rachel - Would you like to talk to us?

Ben - Is the child spirit that followed me with us?

Andy - Do you like following Ben?

Jason - Are you wondering what we are doing here?

Laura - Is there a lady here?

**20:46** MARIA - Why are you here?

Dee - We're not doing anything bad. We're not practicing witchcraft. (Dee answers that the team are trying to communicate then strongly feels the need to mention that they are not practising witchcraft or anything bad).

**MARIA – Scared**

Dee - We're not doing anything scary; we are not evil or anything - we're not communing with the Devil or anything like that.

Rachel - Are you scared of us, or someone else?

**MARIA - Are you soldiers?**

Dee - We're investigators. We're curious.

**20:47** Andy - Can you tell us how old you are?

MARIA (immediately) - Young

20:48 Andy – How Young?

MARIA (immediately) – Eight

Dee feels this is right (as she had mentioned that age earlier in the evening).

Andy – Do you have a name?

Rachel - Do you go to school here?

MARIA (immediately) - No.

Laura - Are you a girl or a boy?

MARIA - Farming

Ben – Are you from this area?

MARIA (immediately) – Yes

20:49 Dee – What is your name?

MARIA – Sam

Ben – Are you a girl or a boy, Sam?

MARIA (after a slight pause) – Boy

Ben - Were you poor?

MARIA - Farm

Andy - Do you have a sister?

MARIA - Horse... Church

20:51 Ben – Did maria hear your horses not long after we arrived? [Maria had reported hearing horses earlier in the evening and went outside to investigate]

There is a pause then Dee hears the word "soldier" in her ear at the same time as Maria says...

MARIA – Soldier

Ben – Do you think we're soldiers, Sam?

MARIA – They came.

Ben - What year?

Dee - Who is on the throne?

20:52 Rachel - Did the soldiers hurt your family?

Dee hears in her right ear (and mentions) "They took our food".

MARIA – Fire

20:53 Ben - Did you die in the fire?

MARIA - No

Rachel - Did you lose everything in the fire?

MARIA (after a pause) – Witch

Dee says quietly to the team "She's not talking about burning a witch is she?" ... then later adds "They didn't do that around here, did they?" to which Jay responds "No, they didn't."  
[HISTORICAL NOTE: they didn't burn witches in England, they hanged them.]

Andy - Sam, do you have a surname?

Ben - Are you the only spirit here?

**MARIA – Go now.**

**20:55** The clock on the wall suddenly whirrs to life and chimes the hour - even though it's five minutes too fast... it made the team jump, however!

Andy - Is there any other spirit that wants to talk with us? Is there someone from Bedford prison?

Laura - Is there someone here called Jane? (She says she is getting that name strongly)

Dee – Who are you, Jane?

Rachel - Would you like to talk?

Ben - How old are you?

MARIA says she can hear someone laughing.

Andy - Is there a highwayman with us?

Jason - Jane, are you with us?

Laura - Are you scared of us?

**20:57** Dee - What colour are you wearing, Jane? (Dee feels this is relevant/significant.)

Rachel - Are you with anyone else?

Ben - Are you Sam's mother?

Maria has not responded for a while then mentions that it has got cold down at her end of the room, and she has a cold breeze down her leg. Andy sends Dee to check out the claim in case she can pick anything up (psychically).

Ben - Did you work on a farm?

**20:58** Dee inadvertently frightens Maria (she couldn't hear Dee coming) and her cry frightens Dee! Dee verifies that it is cold down where Maria is sitting, but she is not convinced that the cold/breeze is not related to the window that is next to Maria.

**20:59** Andy - Are you wearing blue?

Andy explains that he asked that in case 'Jane' is a blue nun. Dee mentions that's interesting, because she asked earlier about what colour Jane was wearing because she felt colour was important in what she was wearing.

**MARIA – Watching**

Jason - How old are you?

Rachel - Are you a man or woman?

Laura - Is there anyone else who wants to speak!

Dee - Are you a nun?

**21:00** Maria ends her stint in the headphones, because it's getting too cold down that end of the room for her. Rachel volunteers to take over.

**21:01** End of session.

---

**Session 3: Same area - SB7 with headphones & blindfold (21:03 - 21:22)**

This time Rachel is the one seated at the far end of the room with her back to the team and the SB7 playing through the noise-cancelling headphones.

**21:03** Maria - Can you come forward again? We'd like to know why you are here.

Ben - Are you still here, Sam?

Dee immediately whispers "Yes" because she heard that in her ear and is still sensing a child nearby.

Andy - Sam, do you have a friend?

**21:04** RACHEL – Sorry

Maria - Was it you making me feel cold?

Laura - Can you tell us why you feel sorry?

Dee - Why are you drawn to Ben?

Maria - Is Ben a cavalier?

**21:05** Ben mentions that he is picking up on a smell of decay.

RACHEL (after a pause) – Kids

Ben - Is that kids making the smell?

Dee also smells something unpleasant, too, but to her it smells more like 'old flowers'. To Ben it smells like "when you drive past a dead badger at the side of the road"!

Maria - Is that you making that smell?

Andy - Can you show yourself?

**21:06** Ben - Sam, make a cat ball light up. Show us you're here.

Dee – It's not magic or anything...

RACHEL - Mistake. John.

Dee is surprised, as that is the name she picked up on soon after arriving at the venue. Dee ventures as far as saying that she thinks the little boy's name is John... (though the boy has not given her his name directly, Dee is still sure there is a connection between 'John' and the child).

Maria - What was a mistake?

**21:07** Andy - Is your name Bunyan?

RACHEL - The devil.

Dee reassures that the team that this doesn't have anything to do with The Devil and that we are here to talk, not anything else.

Maria - Was he the devil?

Dee - We just want to talk to you.

**21:08** RACHEL - The past.

Andy - Can you make it cold up here?

Maria - What was in the past.

**21:09** Andy – How many of you...

**RACHEL** - They're coming.

**21:10** **RACHEL** - Food

Dee reminds the team about hearing 'they took all the food' earlier (at 20:52)

Ben - Are they going to take your food?

**RACHEL** – Walk... Nothing

Andy - Are they here?

Dee 'hears' that the horses were taken too.

**RACHEL** – Help

Maria - What do you want help with?

Dee - How can we help you?

**21.11** Ben - Are you frightened?

**RACHEL** – I lived.

Ben – Did they attack you?

**RACHEL** – Bodies

Maria wonders if that is why Ben could smell decay earlier.

Ben - Did they kill people?

**21:12** Laura - What colour are their uniforms?

Andy - Are you wearing shoes? (He's getting an image of bare feet)

Maria - Are you a Cavalier or Roundhead?

Dee - What kind of helmets are the soldiers wearing?

**RACHEL** - Horrible

Dee - It that because of the dead bodies?

Andy - Is it winter?

Dee - Did you come here [to escape the] ---

**RACHEL** - Terrified

**21:14** Ben - I take it something bad happened here, didn't it?

**RACHEL** (immediately) - Blood Lust... Got up

Jason - Did you run away?

Dee hears 'hiding' in her ear.

**21:15** Laura - Where did you hide?

Andy mentioned that he got the word 'raped'.

Ben - were you hidden in this building?

Andy - Were you raped?

**RACHEL** - Purpose... Good

Andy - Why is it good?

Jason - What year did this happen?

**RACHEL - Leopard**

Dee wonders if 'leopard' could refer to a crest/coat of arms?

Andy - Did you kill anyone?

**RACHEL - Running**

Dee - Are you alone?

Dee - This is not the child who's talking.

Ben - No, Sam's not here at the moment.

Dee - His name's John.

**21:17 RACHEL - Come to**

Maria - Were they soldiers?

Laura - Can you give us your name?

**RACHEL - Why would you say that?**

Dee - We want to know who you are. We're very sorry.

Maria - Is this Tudor times?

**21:18** After several different questions, **Rachel says to the team "It kind of sounds like there are two different voices arguing, almost."** The team notes that as interesting.

Andy – Are there two spirits here?

Dee begins to say, "I've just heard a really----"

and **Rachel** interrupts with **"Not finished with you" (?)**

Dee was saying that she heard a really loud voice in her ear shouting "Burn them all!" Andy then asks if this is to do with a witch and Dee doesn't think so... but the voice gave her chills - very spooky.

**21:19** Andy - Is this to do with Catholics?

Dee remarks that that is a very sensitive subject. Andy justifies the question as seeing if it's religious persecution [being alluded to]. Dee suddenly hears a man's voice and indicates in front to the right.

**RACHEL (suddenly) - My way**

Jason - Who is the king, or queen?

**RACHEL - A verdict**

Dee – What was the verdict?

Ben - Are you connected to one of these jail doors?

(doors from Bedford Gaol are on display at the museum)

**21:20** Laura - Were you on trial here?

Dee - Did you stand before a judge?

Dee wonders (out loud) if they held sessions in here [Moot Hall].

Andy - What is the name of the judge?

Laura - Did you go to jail?

Maria - Were you wrongly accused?

**RACHEL - Anything**

**21:21** Dee suddenly senses a man's presence very strongly (indicates in front/to her right) ... and he's quite... STERN. He's not nice and friendly. Ben asks if he's a vicar, but Dee doesn't know. She is somewhat spooked by him and has goose pimples.

Andy - Are you a vicar?

Maria - Are you a monk?

Dee is very sure he is not a monk. Dee confirms that she does not like this energy at all.

Ben - Back away from Dee, please.

**21:22** Rachel pipes up that her arms are tired from holding the headphones, so the team decides to end the session. The presence is still bothering Dee to the point where she doesn't want to put her back to him.

**End of session.**

---

**21:25** – During the break, Andy's MEL meter starts working again. Previously dead batteries now have full charge again.

---

#### **Session 4: The Bunyan Room**

This small room has a large dining table in the centre, set out as if for a meal. There is a large ingle-nook fireplace behind it, opposite the door with a stew pot set up as if the meal is being prepared. All the team, except Jason sit around the table. Jason is stood in the corner of the room taking notes.

Dee does not take notes during this session due to trying to tune in to the energies in the room. The 'Stern Man' is hovering around. Dee frequently feels the need to reassure that the team is not evil, is not doing anything to do with Devil worship, no witchcraft is being practised and there is no intent to cause harm or distress. Dee is very sure that religion is very prevalent, as she hears several children reciting the Ten Commandments and "the Catechism". The Stern Man is not very comfortable with what the team are doing and is making this known.

**21:55** - Music box experiment – A musical box is played in the hope that it might serve as a 'trigger' device. Various questions are called out while an EVP voice recorder is running.

Maria - In there anybody wants to talk to us? Make a noise.

Andy - Can you make the needle go up?

Rachel - Approach it. Touch it.

Maria - Did you like a simple life?

Andy - Can you touch one of us? Rachel would be good!

(laughs)

Laura - Can you see the green light? Come closer, make it brighter.

Maria - Are you afraid of Royalists?



Rachel - Or Catholics?

Maria - Are you afraid of Roundheads?

Dee - I'm not sensing anything.

Andy - Can you make something move?

Ben - Are you here, Sam?

Maria - Have you got rabbit stew cooking?

**22:00** Cat-ball toy on table lights up.

Rachel - Come towards the light. (Cat-ball toy lights up again)

Laura - Can you set off the ball in the music box?

Maria - Can you make a knocking noise? Can you copy me? (Maria knocks three times)

Can you knock back? (Maria knocks three times again)

**22:02** Andy's watch beeps. It's the hour chime, two minutes late.

Maria - Come sit next to Ben. You seem to like Ben. Does he make you feel safe?

Andy - Can you make one of the objects on the table move?

Maria - We won't be scared. Just...

Rachel - Did you used to sit by the fire and keep warm?

**22:05** Movement is heard coming from one of the upstairs rooms. The only people in the building are the LPS team and due to the layout and size of the building, it is not possible for anyone else to have entered without being noticed.

Dee hears a man with a stern voice say, "You people are ridiculous".

Andy - Stern fellow, can you show yourself?

Laura - Can you make a noise?

Ben - You're curious, aren't you?

Maria - Do you want us to come upstairs?

Dee - I think the stern fellow is worried about what we're doing.

Andy - Are you the vicar from across the road? (Who stops spirits from communicating)

**22:10** Andy - Come show yourself. Is there anybody here wishing to communicate? My name is Andy...

The rest of the team introduce themselves by name. Rachel coughs, causing the cat ball on the table to activate.

Andy - Were you an ex-prisoner?

Rachel - Are you a puritan? Are you a Protestant?

Maria - Are you a druid? Are you a pagan?

Rachel - Are you a Catholic?

Dee hears "Yes"

Dee - He's not sure. He doesn't know what a puritan is.

Maria - Are you from puritan times? Do you know Lord Bedford?

Andy - Were you here when Elstow Abbey was knocked down?

Maria - Do you think we're devil worshippers?

Dee - He won't come in here.

**22:15** Rachel feels something touch her face.

Maria - Are you the man who protects the graveyard?

Dee hears the name 'Matthew'

Jason - Is Matthew your name?

Maria - Please don't be afraid.

Dee - He's not afraid but he's concerned about what we're doing.

Jason - Would you be shocked to learn that I am Catholic.

Dee - So am I, although lapsed.

Both Dee and Jason confirm that they are no longer practising, having both lapsed long ago but are still technically Catholics.

**22:18** A chill is felt around the legs of those seated at the table. Maria checks up the chimney.

**22:20** End of session.

---

### Session 5: Upstairs

Temperature = 18.9°

This is a large room running almost the length of the building, with two small rooms at one end. There is a large, long oak dining table in the centre, a few tables and display cabinets along the edges and an antique bed in one corner.

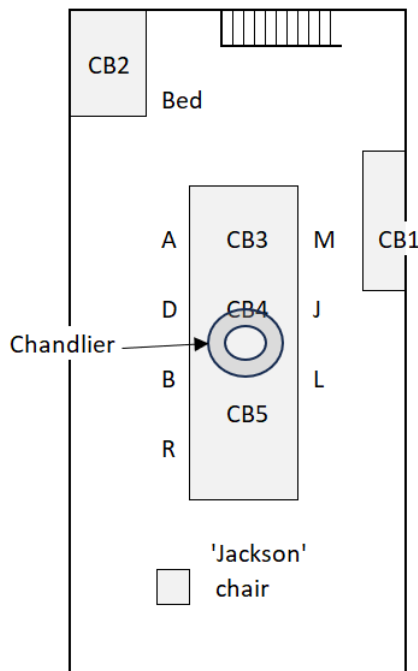

[Diagram, not to scale, showing positions of the seven LPS team members around the dining table and five cat-ball motion detectors.]

Dee hears the name "Jack/Jackson" frequently. J-names. At the end of the session, when the lights come on and everyone begins packing away equipment, Dee wanders around the far end of the room and is amazed to find the name "Jackson" carved into the back of one of the antique chairs.

Maria - Would anyone like to come forward? We mean you no harm. We're just intrigued. My name's Maria... (rest of team introduce themselves by name).

**22:29** Catball behind Maria and Jason (designated CB1 hereafter) is activated.

Dee - I promise we are not doing anything evil or bad.

Maria - If you are a man, can you light up the balls?

**22:31** Ben places a cat-ball on the bed (designated CB2 hereafter).

Maria - Do you like Charles I? Do you like Cromwell?

CB1 is activated.

Rachel - Are you a Parliamentarian?

Dee - Are you a Royalist, or do you hate Royalists? Are you a man or a woman?

Maria - Did you fight for Cromwell? Did you like or dislike James II?

CB1 is activated.

Maria - Is that because he tried to stop Puritans? \*

(\* Note from JH: I think it was James I that did this. It's why the Pilgrims sailed to America on the Mayflower in 1620. James II was the grandson of James I and king from 1685 to 1688.)

**22:35** CB1 is activated. Flashes continuously.

Maria - Do you want us to leave?

Dee - Can you light the ball between Jason and me? (On the table between them)

**22:37** MEL meter battery is dead again.

Dee, sitting opposite Jason asks him if he felt a bump on his leg. Jason says he didn't.

Laura - Can you light the ball on the bed?

Andy - Can you make the chandelier move?

Andy (to Rachel at the opposite end of the table) - How is it down your end, Rachel?

Rachel - Weird. I'm not feeling anything.

Maria - Are you annoyed that we're here?

Rachel - Are you able to light the ball in front of me? Was it you making creaking noises earlier?

CB2 (on the bed) is activated.

Dee Hears "Not my bed".

Andy - Where's the stern person?

Dee - I think he's trying to keep quiet because I can hear him. I don't sense children here at all.

**22:42** Dee - Are you drawing energy from us, or from our equipment?

Andy - Can you bring our dinner up? (joke)

Dee - I think he's trying to keep quiet because I can hear him.

Maria - Can you knock on something?

22:44 CB2 on bed is activated during a conversation about a vicar or priest.

Maria - Are you the religious man? Did you have an affair? Are you protecting someone?

Laura - Did you die in that bed?

22:47 CB1 is activated.

Dee - If you passed away in that bed, can you light up the ball?

Maria - Did a child die in that bed?

22:48 CB1 is activated.

Maria - Was he a little boy, or a girl? – CB1 is activated.

Maria - Was it a girl? (pause) Was it a little boy called Sam?

Dee - Or John?

Maria - A little girl called Samantha?

Dee - Or a woman... A grown woman?

Maria - Use our energy.

Maria - A little baby? (Then, to the Team) Is anyone buried out there?

Dee - Are you connected to any items here, or the building?

Rachel – Or the church?

Dee says that she can hear children chanting. It sounds like they are reciting the Ten Commandments.

**22:51** Ben sees a shadow moving near the stairwell.

**22:53** Session is paused.

**22:55** CB1 and CB4 (in the middle of the table) are swapped to see whether CB1 continues being activated in its new position, which might indicate a faulty LED, or if CB4 is now the cat-ball that is repeatedly activated.

CB4 had not previously been activated during the session. It is now activated three times in its new position, where CB1 had previously been placed.

### **23:04 Session Restarted. Stickman Experiment**

Dee - Is there anyone with us? You are welcome to make contact. We come here with the utmost respect.

The team members once again introduce themselves by name

Dee - We are Luton Paranormal Society. We investigate the afterlife. Is there anything you can do to show us you are here? Can you please light up the ball behind Maria, or the ball on the bed? It's not magic. It won't hurt you.

Maria - Is there a man here? Or a woman?

Dee - Andy is carrying an SLS camera...

Andy (interrupts) - There's something on the wooden beam...

Dee - The camera helps us to see you.

Andy - It's gone.

Maria - Are you the shadow that Ben saw earlier?

Dee - Are you sitting up on the beam?

**23:09** Dee hears a male voice say the name 'Jackson'.

Maria hears the hymn, 'Morning Has Broken' being sung.

**23:10** Dee sees a shadow.

Dee – Can you appear for Andy on the bed?

**23:13** Dee hears the name 'Jackson' again.

At this point Jason stops taking notes due to excessive eyestrain making it impossible to concentrate. Just two more notes follow...

**23:18** Spirit box is switched on.

**23:23** Jason feels very cold.

---

## **Session 6: Lobby**

### **Dee's Notes:**

Andy decides to use the SLS camera at the very end of the investigation before the battery runs out and when he points it at the lobby, a small figure appears immediately on the screen. It seems to be sitting on the floor in front of the end of the reception desk (the main door where the team entered the venue is to the left). The figure seems to be that of a child and does not disappear when Dee approaches. Dee cannot see the figure but can sense the presence (as she has done the whole investigation) and when she reaches her hand down to it, she can feel tingling, like static electricity in her fingers. Very interesting!

---

### **Post Investigation de-brief at approximately 00:30**

The curator joins the team to take down some notes of their experiences and findings and to reveal some of what he knows. Most notably he states that the spirit most often picked up is that of a small boy called John. This is a name that came to Dee repeatedly throughout the investigation.

It is felt that John is a very mischievous spirit who was responsible for opening a security tagged internal door on several occasions while the building was locked up, a few years ago. This would set off an alarm inside the curator's house (across the car park) and he would have to go over to the Hall, unlock it and check the building on each occasion. Various tests had been done on the door to ascertain whether it could open of its own accord, but it was established that a considerable amount of weight needed to be applied to the door handle to release the catch. The problem was solved when a bolt was secured to the outside of the door, and now only ever happens when the person locking up has forgotten to secure the bolt.

Unfortunately, LPS have the distinction of being the last paranormal group to investigate the Moot Hall at Elstow, at least for the foreseeable future.

\*Post investigation note: Thomas Cox, not John. But his uncle is called Jonathon.